

REVISIONS			
REV	DESCRIPTION	DATE	ECO
2	ENGINEERING RELEASE	6-21-07	

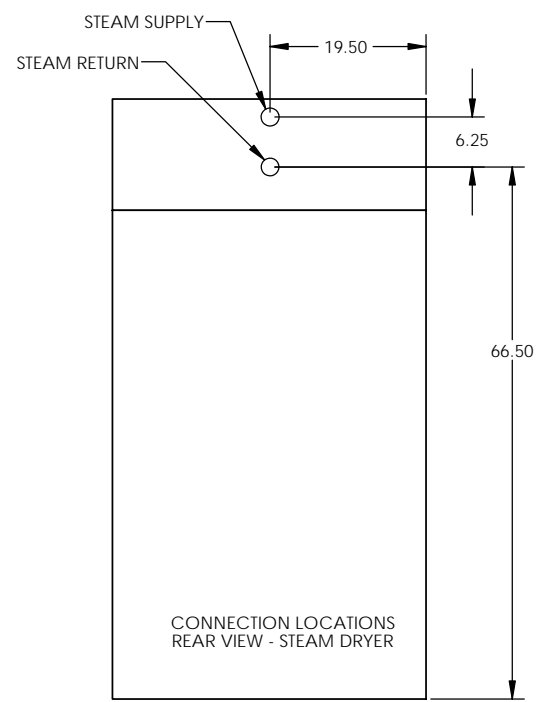
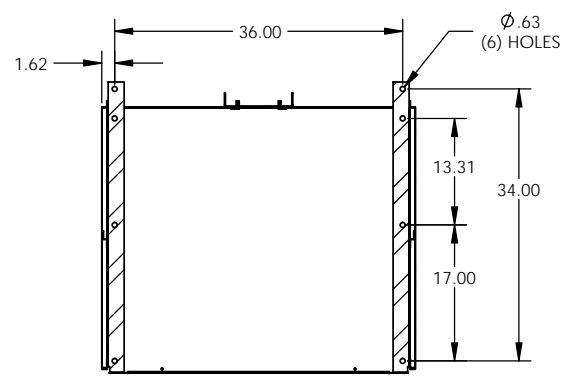
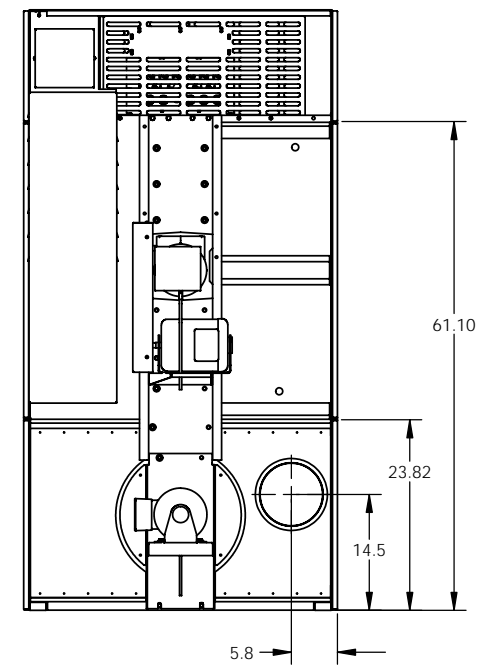
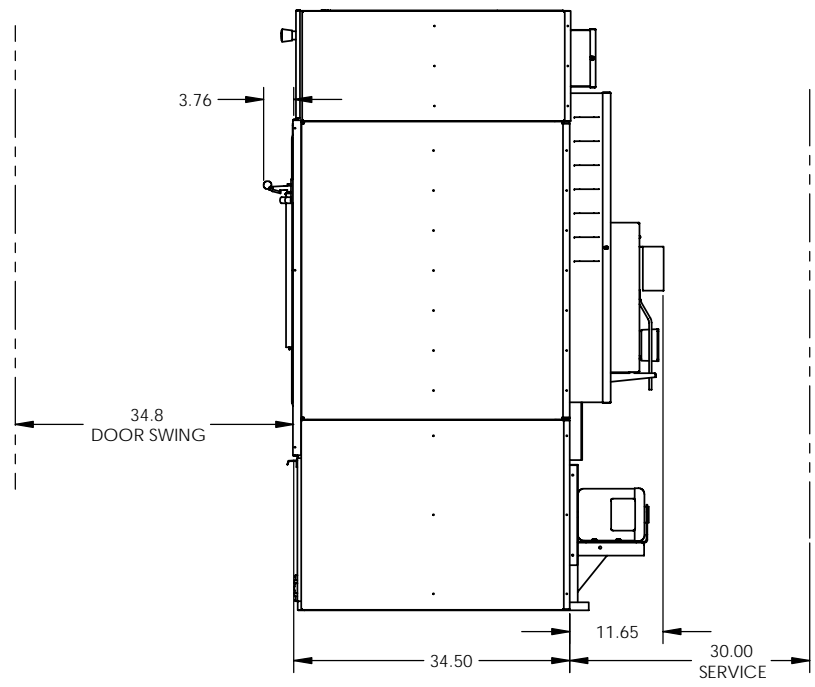
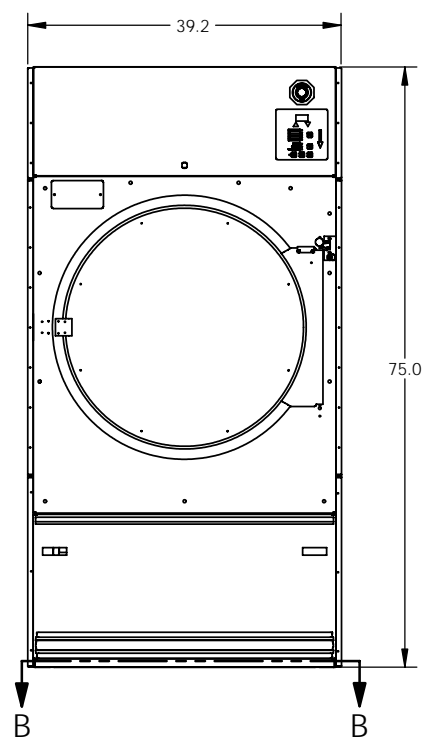

SPECIFICATIONS

M50TDE ELECTRIC HEATED

- HEAT CAPACITY:36KW
- NET WEIGHT:790 LBS
- CAPACITY:50 LBS DRYWEIGHT
- ELECTRICAL:440/60/3 LINE VOLTAGE, w/24V CONTROL VOLTAGE
- TOTAL CURRENT:54 AMPS
- BASKET MOTOR:1/2 HP
- FAN MOTOR:1/2 HP
- EXHAUST DUCT:8" DIA
- RATED AIR DISPLACEMENT: ..750 CFM AT .2" WATER STATIC

M50TDS STEAM HEATED - NINE SECTION

- RECOMMENDED OPERATIONAL RANGE: ...630-730 CFM (11.84-20.67 CU. M./MINUTE)
- STEAM SUPPLY CONNECTION:3/4" (1.91 CM)
- STEAM RETURN CONNECTION:3/4" (1.91 CM)
- OPERATING STEAM PRESSURE:7-15 PSIG (3.18-6.8 KG) LOW PRESSURE
- 125 PSIG (45.36 KG) MAX. HIGH PRESSURE
- STEAM CONSUMPTION:2.7 BHP -90LBS (40.7KG)/HOUR WITH NORMAL LOAD LOW PRESSURE
- 3.4BHP - 117.3 LBS (53.21 KG)/HOUR WITH NORMAL LOAD HIGH PRESSURE

AUTHORIZATION FOR USE THIS DOCUMENT IS AUTHORIZED FOR USE AS SPECIFIED BY THE EDRO CORP. DO NOT USE PREVIOUS REVISIONS WITHOUT APPROVAL. AUTHORIZED BY: _____ DATE: _____		UNLESS OTHERWISE SPECIFIED: DIMENSIONS ARE IN INCHES TOLERANCES: FRACTIONAL: ± 1/16 ANGULAR: MATCH -10° 5' BEND ± 1° TWO PLACE DECIMAL: ± 0.020 THREE PLACE DECIMAL: ± 0.005		NAME: WAW DATE: 2/28/07		 The EDRO Corporation 37 Commerce Street East Berlin, CT USA 06023
PROPRIETARY AND CONFIDENTIAL THE INFORMATION CONTAINED IN THIS DRAWING IS THE SOLE PROPERTY OF THE EDRO CORPORATION. ANY REPRODUCTION IN PART OR AS A WHOLE WITHOUT THE WRITTEN PERMISSION OF THE EDRO CORPORATION IS PROHIBITED.		MATERIAL: Material Quantity		MFG APPR: _____ DIA: _____		
DO NOT SCALE DRAWING		COMMENTS:		SIZE DWG. NO. C M50E/S REV 2		SCALE: 1:12 WEIGHT: _____ SHEET 1 OF 1